

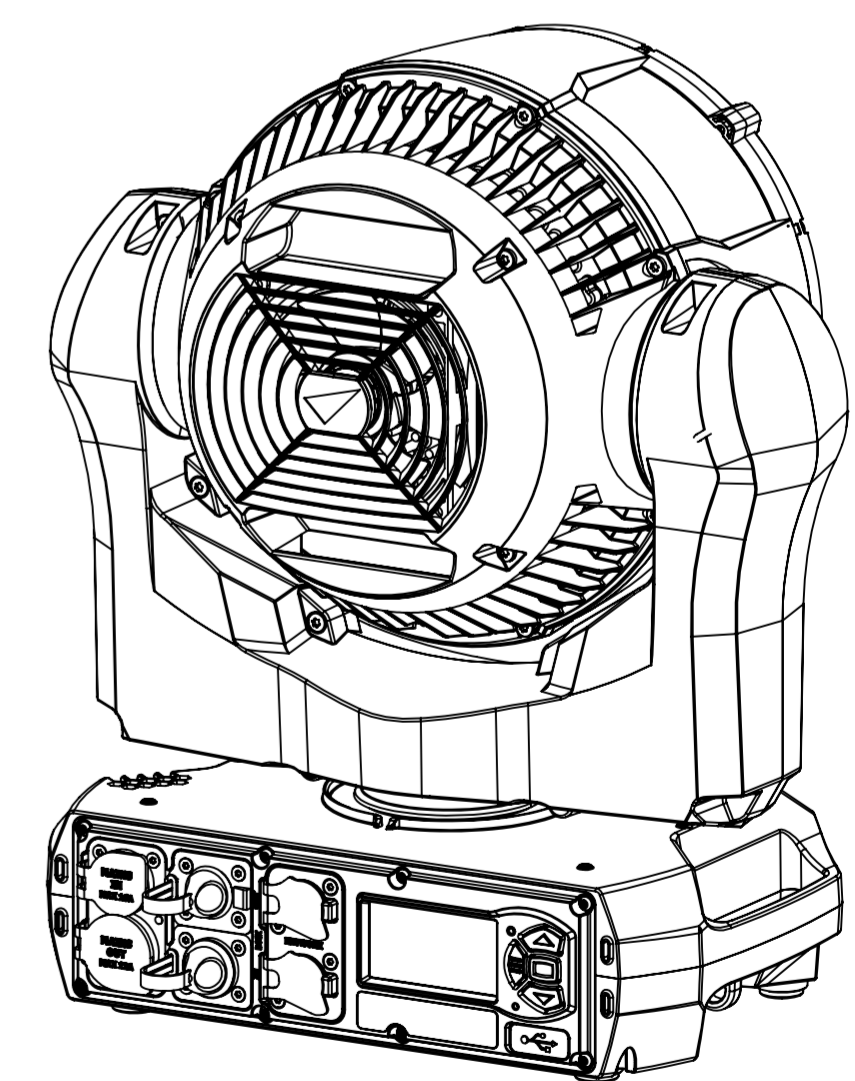

REVISION HISTORY			
DATE	REV.	DESCRIPTION	BY
15-08-2022	A	First release	SherryXie

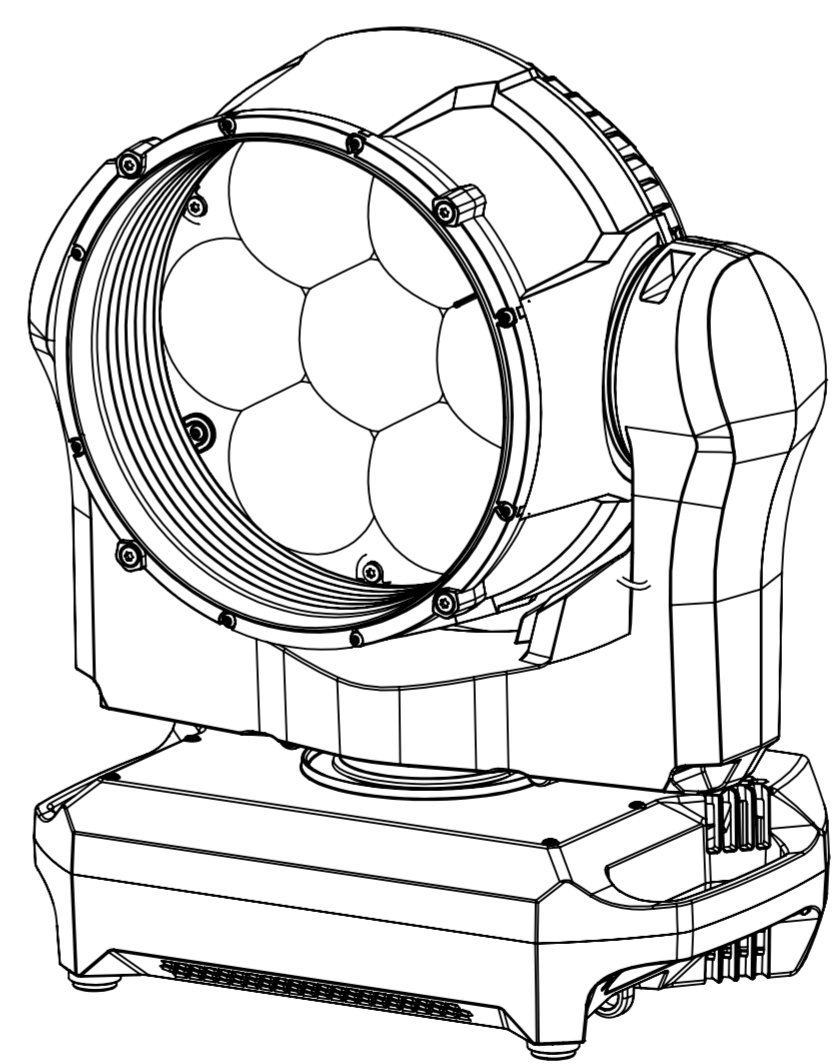
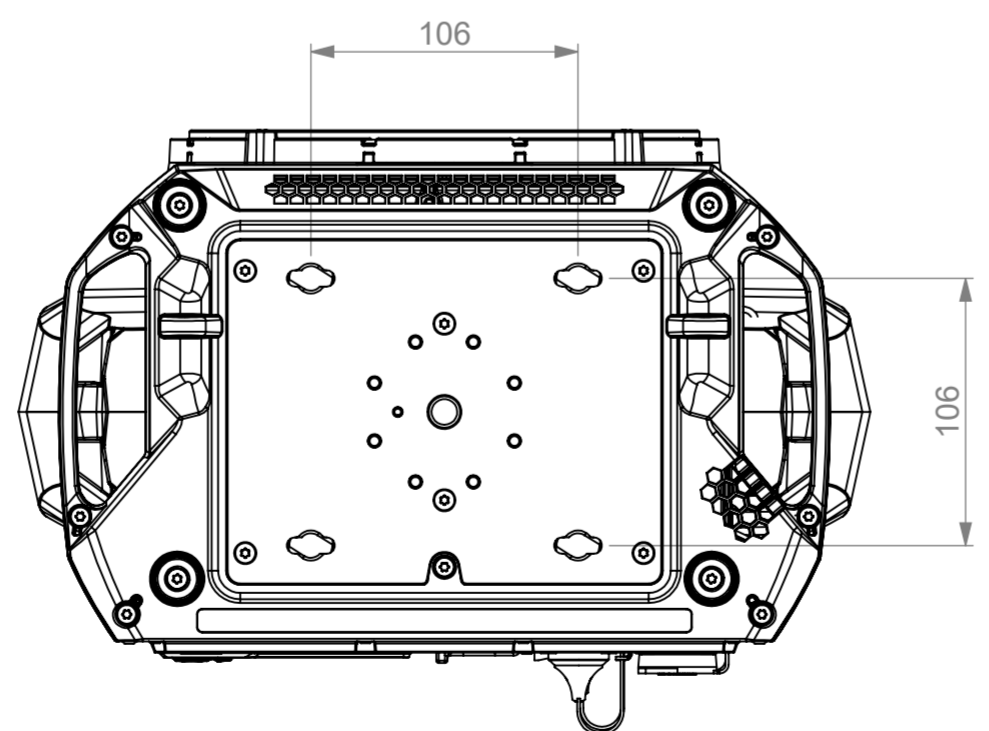
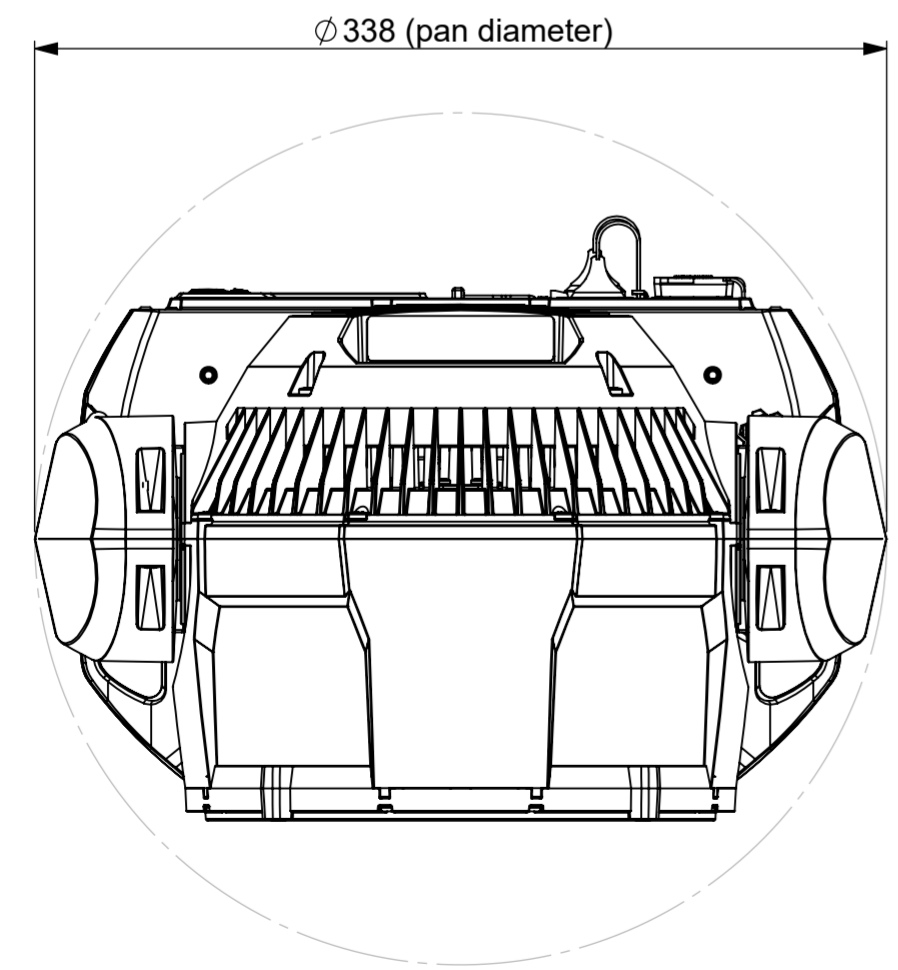
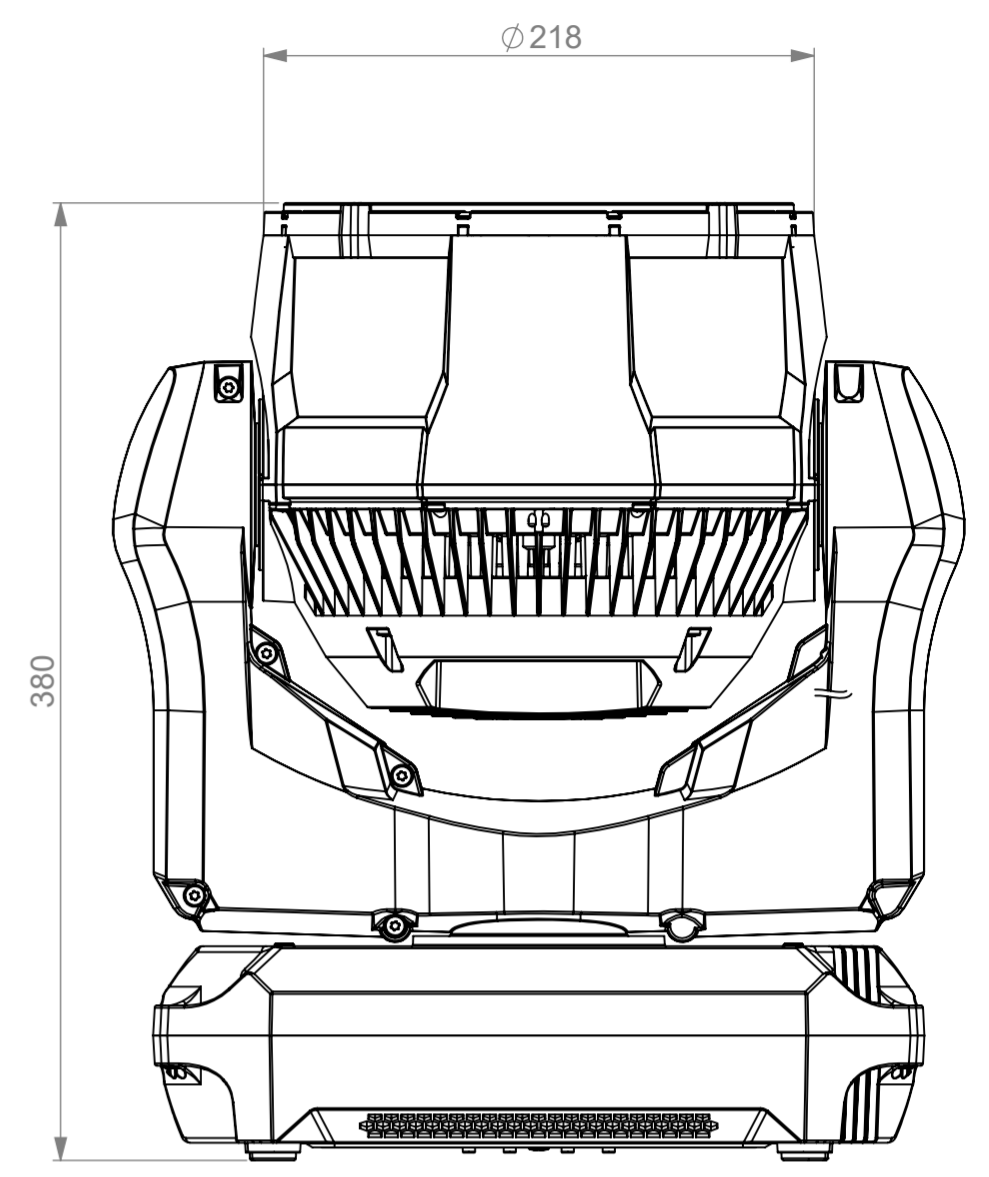
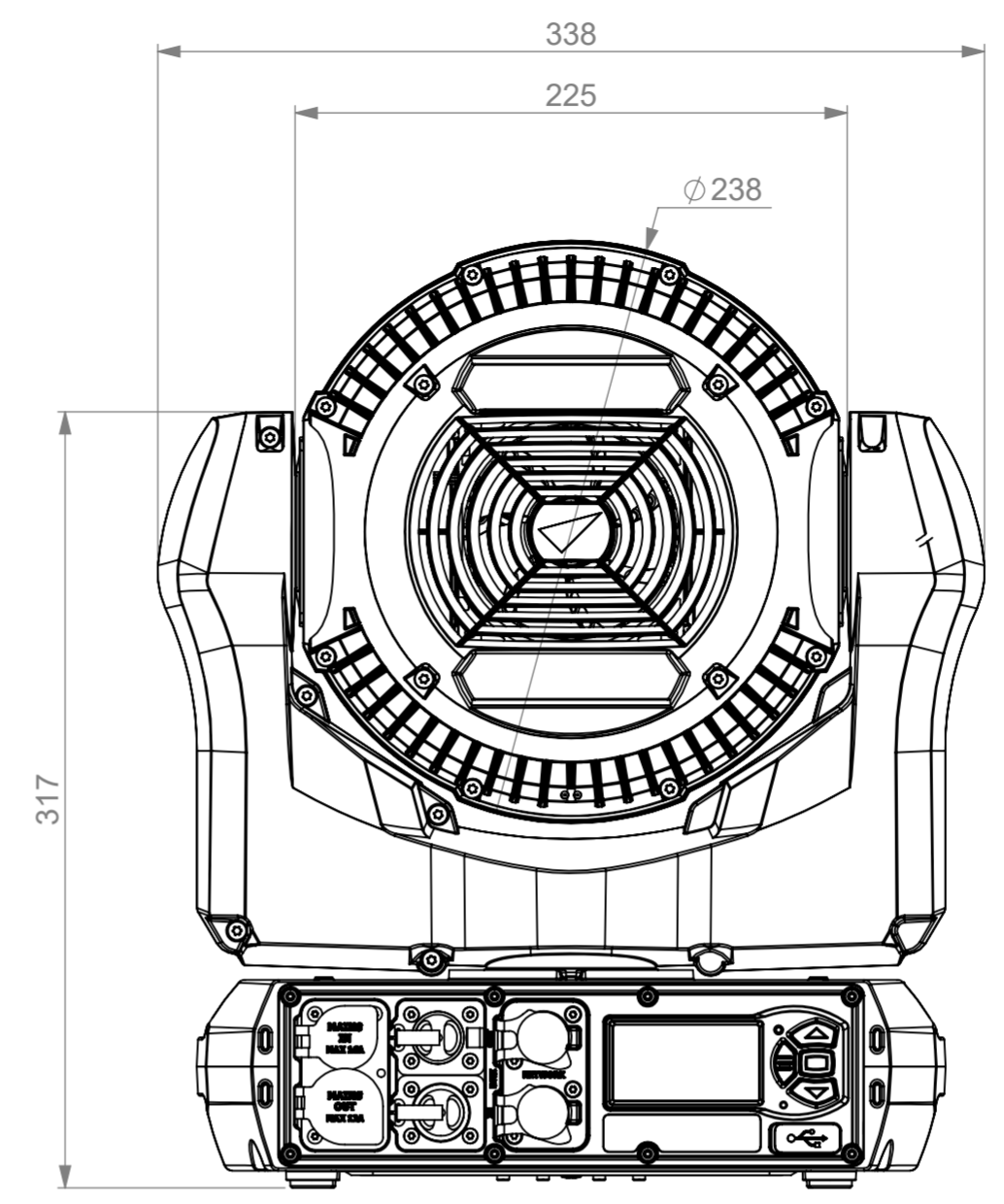
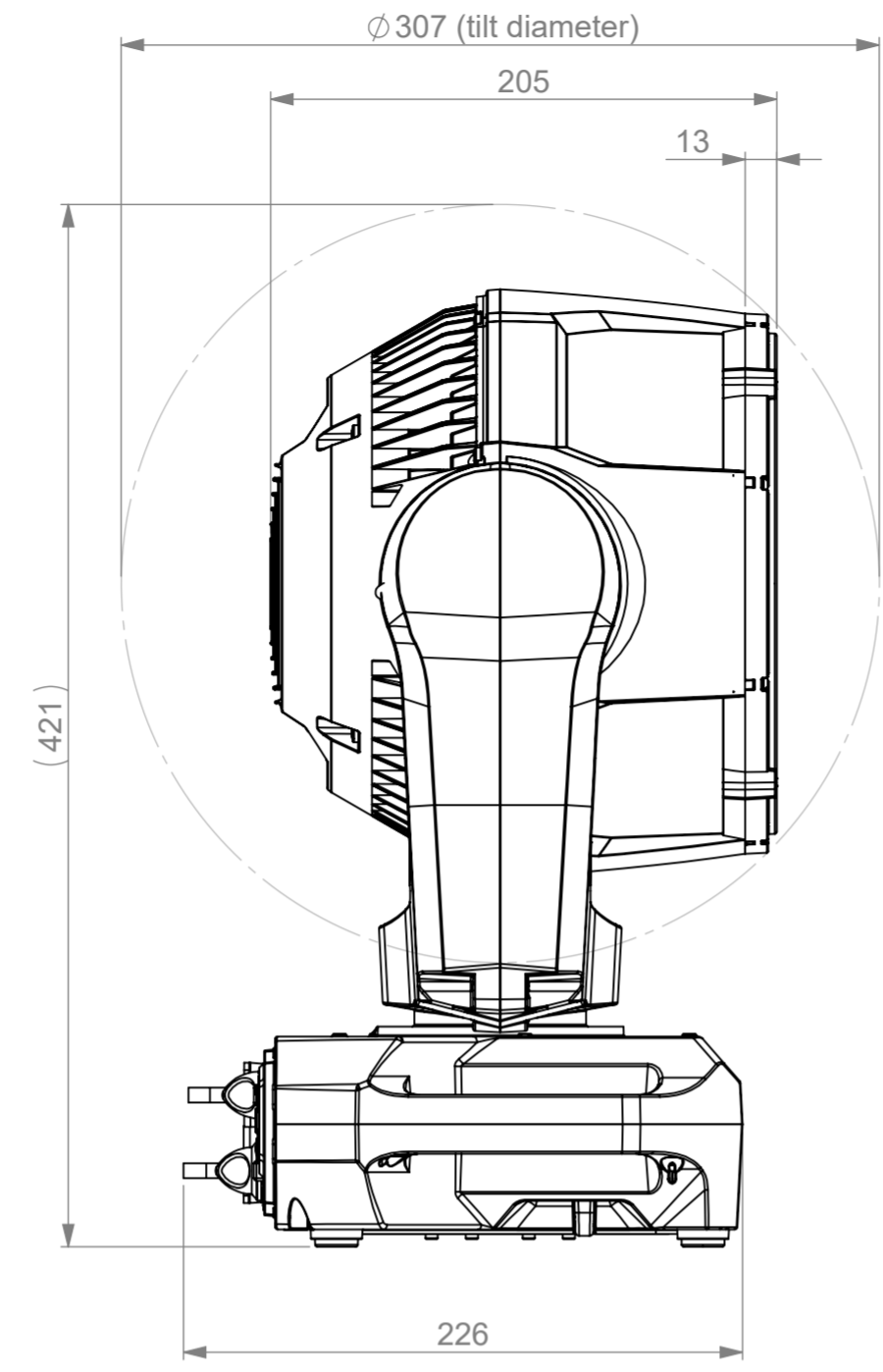
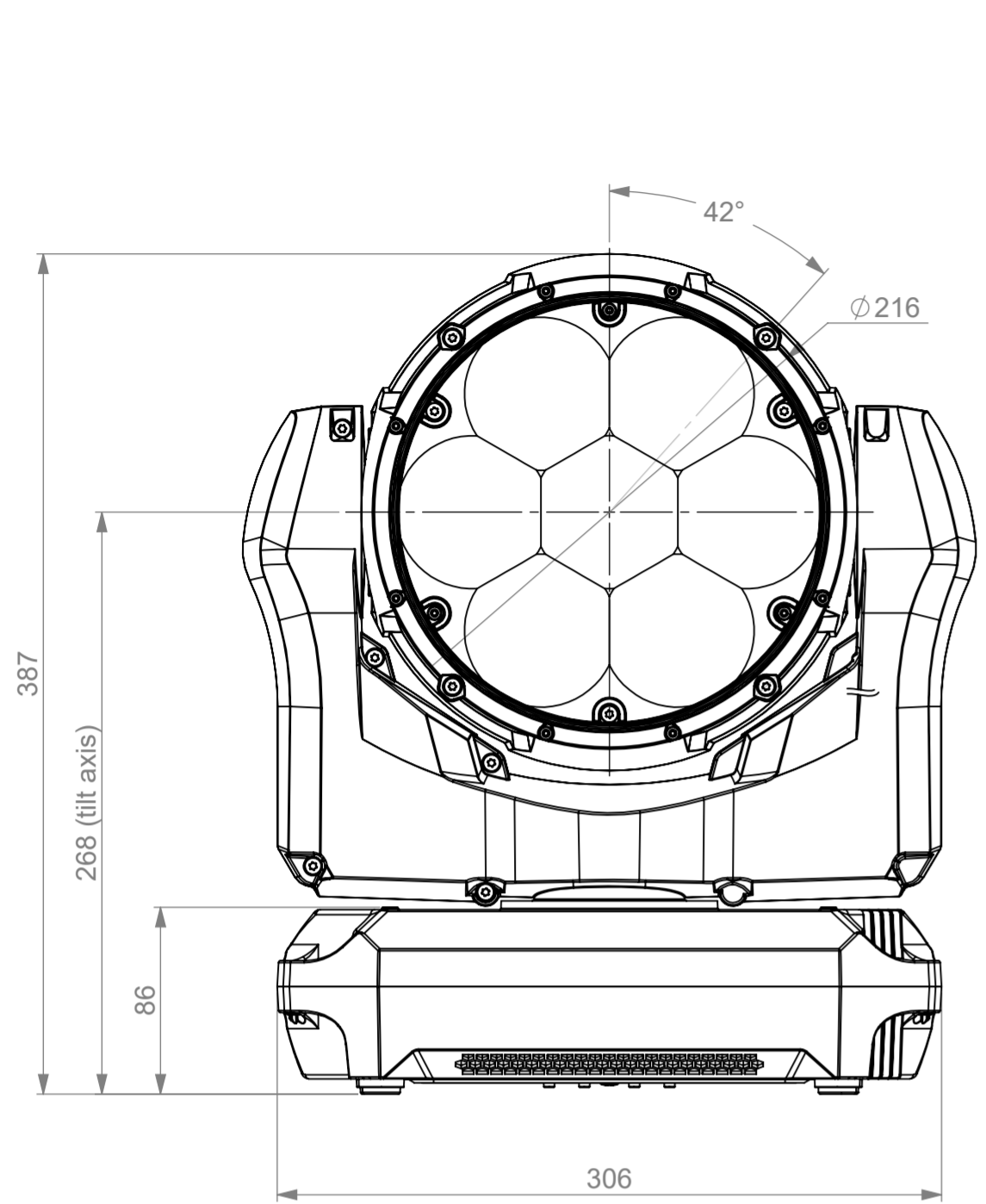
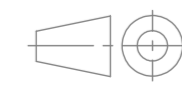

© 2021 HARMAN Professional Denmark ApS PROPRIETARY AND CONFIDENTIAL PROPERTY OF HARMAN. DO NOT DISCLOSE, REPRODUCE, OR PUBLISH WITHOUT WRITTEN HARMAN APPROVAL.	Material	FIRST ANGLE PROJECTION 	 HARMAN Professional Denmark ApS Olof Palmes Allé 44 DK 8200 Aarhus N
	General linear tolerance		
ROHS RESTRICTION OF HAZARDOUS SUBSTANCES ALL MATERIALS USED IN THIS PART MUST BE ROHS COMPLIANT. SUPPLIER SHALL PROVIDE A CERTIFICATE OF ROHS COMPLIANCE WITH THE FIRST ARTICLE.	General angular tolerance	Surface treatment	MAC Aura XIP
	General geometrical tolerance	Color	NO. 5131347-00 REV
	DIMENSIONS SHOWN ARE FOR REFERENCE AND INSPECTION ONLY. REFER TO CAD MODEL PROVIDED WITH THIS DRAWING FOR OVERALL DEFINITION OF PART GEOMETRY.	Project number	SIZE A2 SCALE 1:3 UNIT mm DO NOT SCALE DRAWING SHEET 1 OF 1